



**PHOENIX VINYL**  
PRODUCTS

PROFESSIONAL SERIES

# Privacy Panel and Gate

Post Mount Installation Instructions

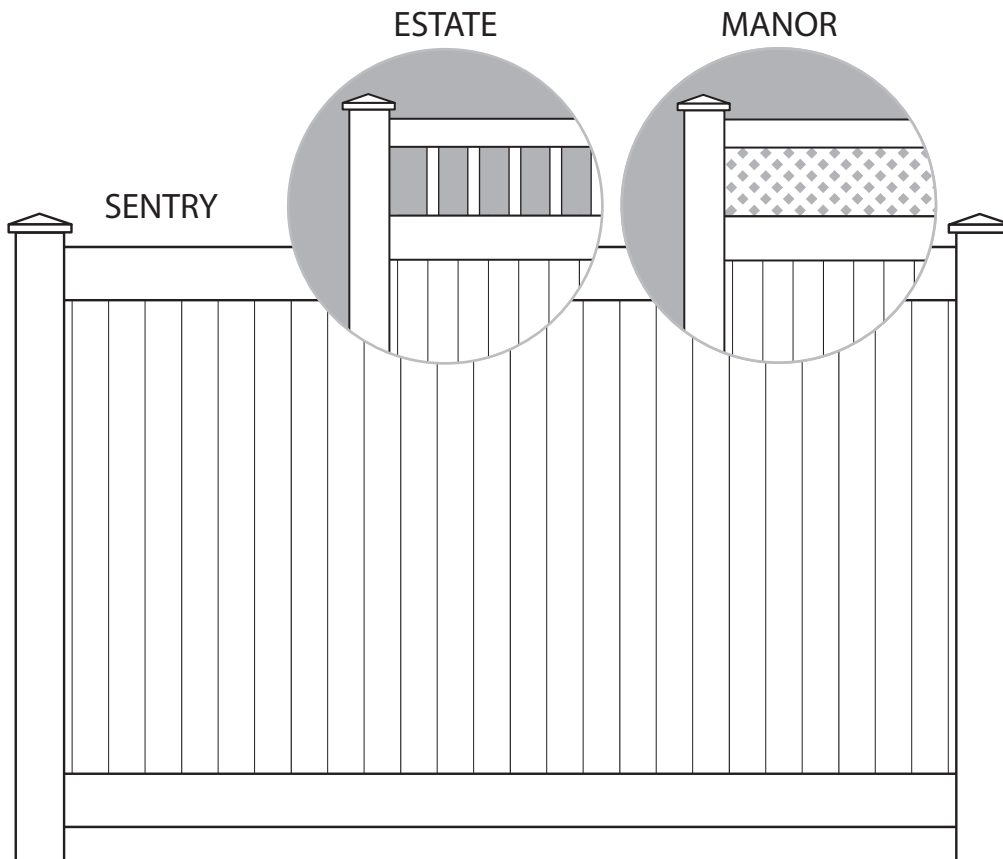

**Before you start, it's important to check...**

That fence footings do not exceed legally established property lines. If uncertain, refer to real estate agent's line plot or consult a professional surveyor.

Local codes for specifications regarding frontage locations, allowable fence heights, etc. A permit may be required.

With local utility companies for locations of underground cables or pipelines.

**Parts List**

**EACH 5' & 6' HIGH SENTRY PRIVACY PANEL INCLUDES:**

- A. 1-1/2" X 5-1/2" Routed Rails (2)
- B. 7/8" X 11.3" Tongue and Groove Pickets
- C. 7/8" PVC U-Channel (2)
- D. Galvanized Steel Insert (1)  
(for 8' on center post spacing only)  
#14 X 1 1/2" Self Drilling Hex Head Screws (6)  
- Not shown
- E. 1-7/8" O.D. X 8' Long H.D. Galvanized Pipe
- F. Post Mount Sockets Assembly (Outer & Inner Ring) (2)

**Estate**

- G. 2" X 3-1/2" Top Rail
- H. 7/8" X 1-1/2" X 12" Accent Pickets

**Manor**

- I. 2" X 3-1/2" Top Rail
- J. 12" X 6' or 8' Lattice

**Tools and Equipment Required:**

- Tape Measure
- String Line
- Shovel
- Manual or Pneumatic Post Pounder
- Electric Saw (possibly to cut down components for short fence sections)
- Hand Auger (to cement in Gate Hinge Posts)
- Level
- Electric Drill

**GENERAL INFORMATION:**

Read this instruction sheet completely before starting work.

During panel/gate assembly, work on a soft, non-abrasive surface to avoid scratching the PVC.

When cutting PVC components with a power saw, use a fine-toothed blade (plywood blade, finishing blade, etc.).

Laying out the fence is the critical first step toward ensuring a quality installation.

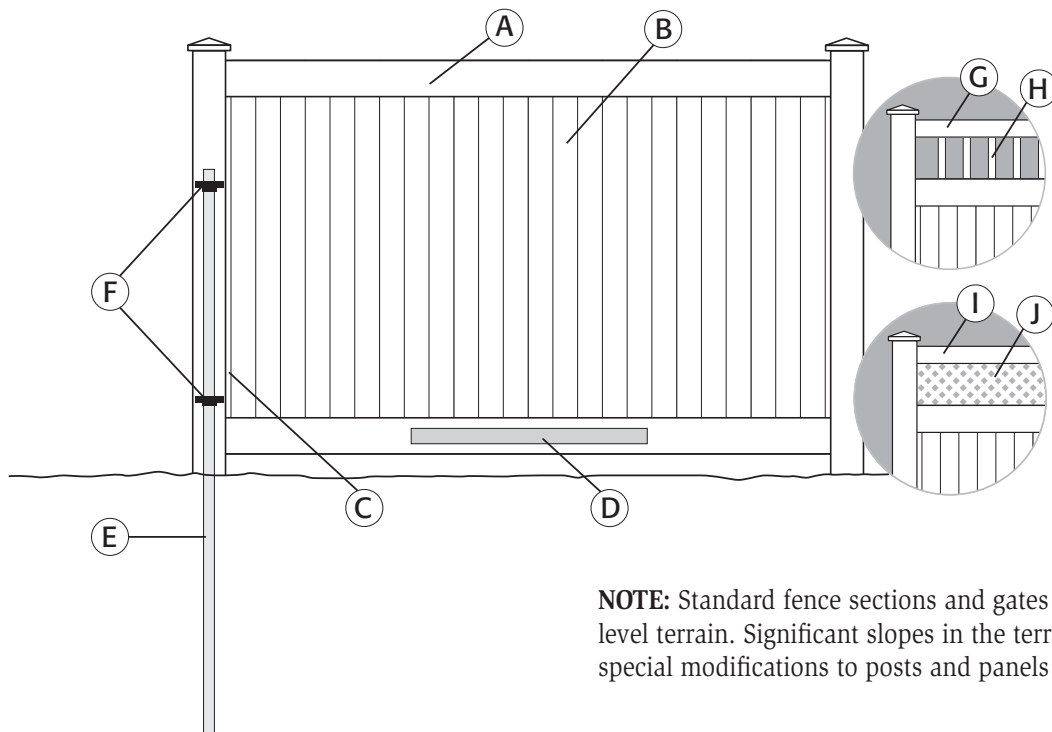

**NOTE:** Standard fence sections and gates are designed for level terrain. Significant slopes in the terrain will require special modifications to posts and panels (see Section 5).

**1 Prepare Fence Layout**

**STEP 1**

Locate the boundary lines to your property.

**STEP 2**

Drive stakes into the ground along the property line and stretch a string between each stake.

*Be sure to extend the string about 24" beyond the property line (Fig. 1).*

*It is recommended that all posts be set approximately 6" inside of the property line so that fence posts do not encroach onto the adjacent property.*

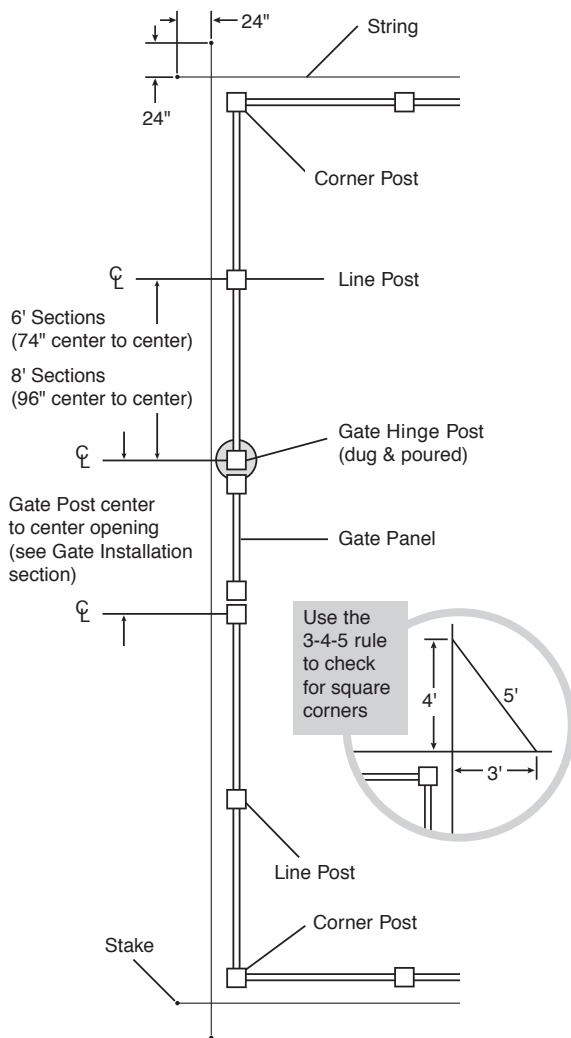

Figure 1

**STEP 3**

Mark the location of each terminal post with a stake (Corner, End and Gate posts are called *terminal* posts).

*When determining the position of the gate posts, refer to Section 10 – Gate Installation for actual gate opening.*

**2 Pound in Pipe Posts**

**STEP 1**

Establish and mark out all locations of Terminal Posts and Line Posts. For 8' On Center fence panel sections space Pipe 96" Center to Center (or 94" inside to inside) and for 6' On Center fence panel sections space Pipe 74" Center to Center (or 72" inside to inside) (Fig. 2).

**STEP 2**

Pound 1-7/8" OD (0.083" or Schedule 40 Wall) x 8' Long Hot Dip Galvanized Steel Pipe into ground 4' at all post locations (Terminal & Line). Although it is important to pound the Pipe in as plumb as possible, the Post Sockets Assemblies are designed with lateral offset adjustability. Pounding of Pipe can be executed with a manual post pounder or with a Pneumatic Post Pounder (available through various manufacturers available upon request) (Fig. 2).

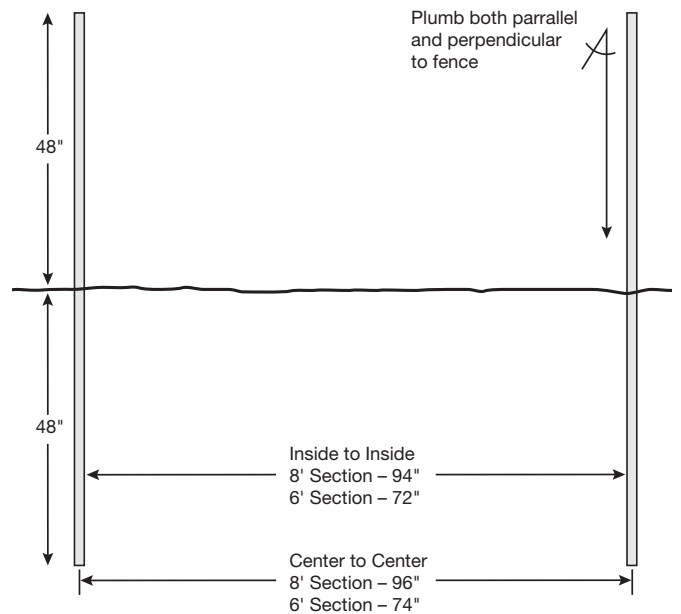

Figure 2

**STEP 3**

**Gate Hinge Post Installation.** It is recommended that "Gate Hinge Posts" are not installed by Post Mounting. Rather, the recommended procedure is to cement a 5" x 5" x 108" Galvanized Steel L-Channel Reinforcing Insert 36" into a traditional "Dug and Poured" concrete pile. Once the concrete is cured, the 5" x 5" Vinyl Hinge post is sleeved over top the L-Channel Reinforcing Insert. This procedure provides added strength for supporting the static and dynamic weight of the gate panel as well as provides a solid backing hinge screws (Fig. 3). Refer to Section 10 Gate Installation.

NOTE: Install L-Channel reinforcing insert with corner oriented towards hinge location on opening side of gate.

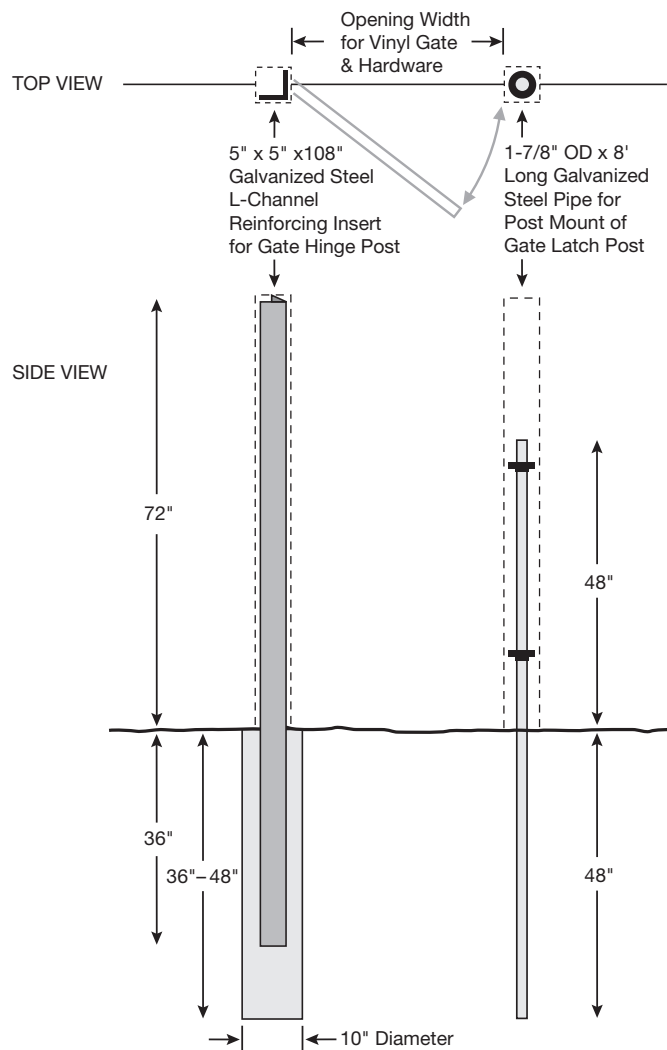

Figure 3

**3 Post Socket Assembly Installation**

Two Post Socket Assemblies are required for each Pipe Post. Each Post Socket Assembly consists of two components; a Small Inner Ring (with outer circumferential spline oriented upwards) and a Large Outer Ring (with splined channel oriented downwards). Each Inner Ring attaches directly to the Pipe with #14 x 1-1/4" Self Drilling Hex Head Screws installed through the lower band of Inner Ring. The splined channel of the Outer Ring mates with the Inner Ring and can be "offset" to provide lateral adjustment for "out of plumb" Pipe Post. Later the Vinyl Post will be sleeved over top and attached to the Top and Bottom Outer Rings with the Self Drilling Hex Head Screws. It is recommended to slip both sets of Socket Assemblies (Inner and Outer Rings) over each Pipe Post prior to pounding into the ground because some lighter wall Pipe may "mushroom" on the pounded end and make it difficult to sleeve Sockets overtop afterwards (Fig. 4).

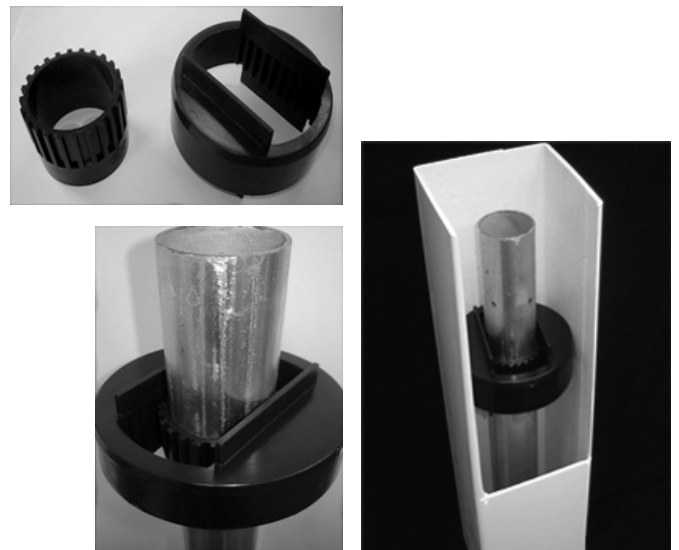

Figure 4

**STEP 1**

**Slip Socket Assemblies on Pipe.** Slip Two Socket Assemblies over all Pipe Posts (Terminal & Line) paying close attention to orientation of assemblies.

**STEP 2**

**Fasten Top and Bottom Inner Rings.** Attach Top and Bottom Inner Rings to all Pipe Posts with Self Drilling Hex Head Screws at the recommended heights below. Final lateral offset adjustment of Outer Rings will follow in later steps.

Note that attaching the Post Socket Assemblies at the following heights will enable an easier and faster installation of the Vinyl Posts and U-Channel later on (Fig. 5).

- Bottom Socket Assembly to be installed approximately 12" above ground so as to be above insertion point of bottom rail into vinyl post
- Top Socket Assembly to be installed approximately 42" to 46" above ground so as to be below insertion point of top or mid rail into vinyl post

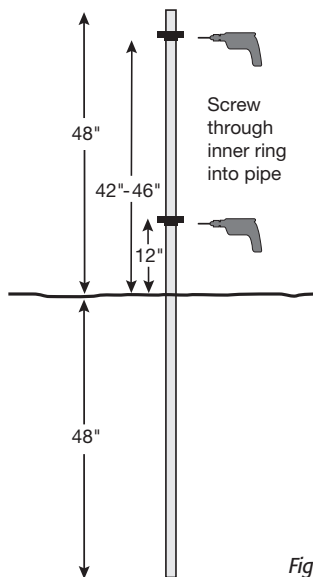

Figure 5

**STEP 3**

**Offset Adjustment of Top and Bottom Socket Assemblies on End & Corner Posts.** Utilizing a Level, adjust lateral offset of the Top and Bottom Outer Rings as required to plumb the Top Socket relative to the Bottom Socket. It is important to set the Outer Rings plumb in both directions (parallel and perpendicular to the fence line) (Fig. 6).

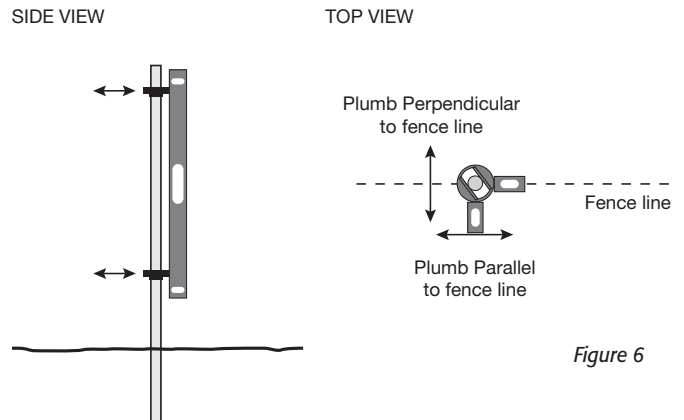

Figure 6

**STEP 4**

**Offset Adjustment of Top Socket Assemblies on Line Posts.** On each fence section, between End and Corner Posts, run a string line tightly wrapped around the outer circumference of the Top Socket Outer Rings. Now, using the string as a reference point, set the lateral offset of the Top Outer Rings on Line Posts (Fig. 7).

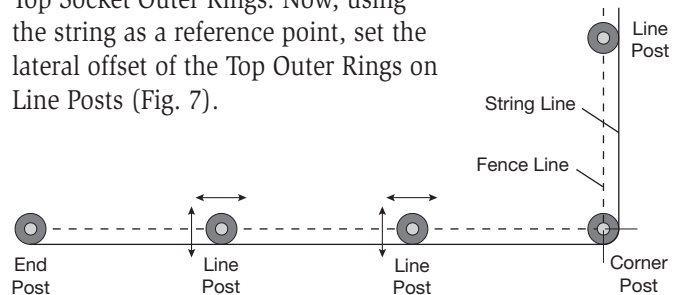

Figure 7

**STEP 5**

**Offset Adjustment of Bottom Socket Assemblies on Line Posts.** Utilizing a Level, adjust the lateral offset of the Bottom Outer Rings as required to plumb the Bottom Socket relative to the Top Socket. It is important to set the Outer Rings plumb in both directions (parallel and perpendicular to the fence line) (Fig. 6).

**4 Installing Vinyl Posts onto Post Socket Assemblies**

**STEP 1**

All Vinyl Posts are fabricated 6" longer than the overall height of the fence (2" gap + 4" below grade). This requires an excavation at base of each Pipe Post approximately 6-8" in diameter by 4-6" in depth (Fig. 8).

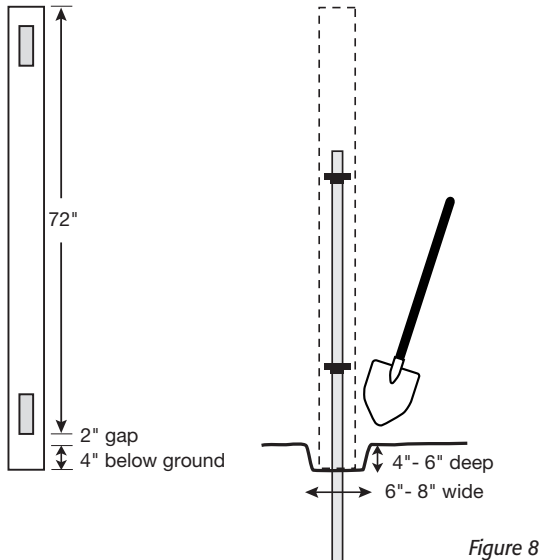

Figure 8

**STEP 2**

Sleeve all Vinyl Posts over the Socket Assemblies with the extended blank end of post oriented down. Ensure that all Vinyl Posts are in the correct position (End, Corner, Line and Gate Hinge).

**STEP 3**

Attach the 7/8" Vinyl U-Channel to all Vinyl Posts. At this point, the Vinyl Posts are not fastened to the Socket Assemblies. Center the U-Channel on the post, between the bottom and top rail cutouts. Secure the U-Channel only at mid height with a #14 x 1-1/4" Self Drilling Hex Head Screw (Fig. 9).

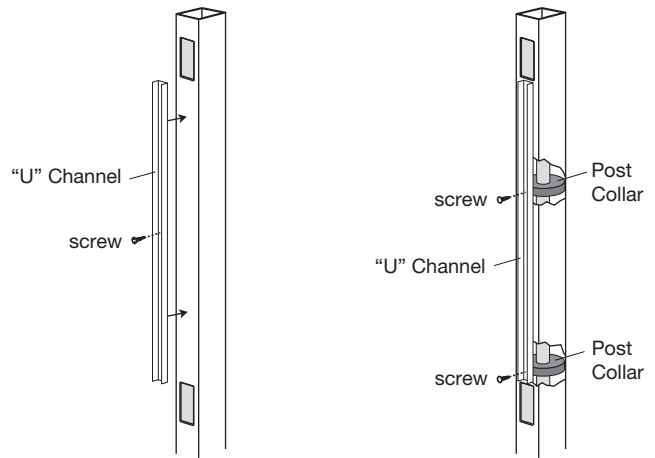

Figure 9

**STEP 4**

**Set all Terminal Posts (End, Corner & Gate) to Elevation.**

Adjust the Terminal Posts to the desired elevation, and secure them with a #14 x 1-1/4" Self Drilling Hex Head Screw through the 7/8" Vinyl U-Channel, Vinyl Post and into the Top and Bottom Outer Rings. Note that previously installing the Post Socket Assemblies at the recommended heights will ensure accurate positioning of screws.

**NOTE:** For sloped/variable terrain installations, refer to Section 5.

**STEP 5**

**Set all Line Posts to Elevation.** On each section of fence, between the Vinyl Terminal Posts (End, Corner & Gate), run a string line. Adjust the Line Posts elevation to the string line, and secure them with a #14 x 1-1/4" Self Drilling Hex Head Screw through the 7/8" Vinyl U-Channel, Vinyl Post and into the Top and Bottom Outer Rings. Note that previously installing the Post Socket Assemblies at the recommended heights will ensure accurate positioning of screws.

**NOTE:** For sloped/variable terrain installations, refer to Section 5.

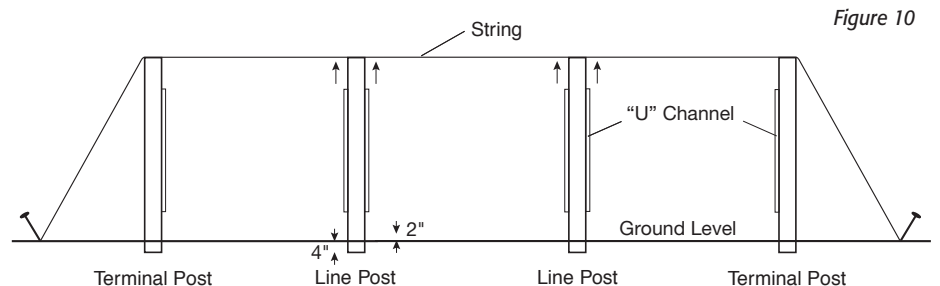

Figure 10

**5 Sloped/Variable Terrain Installation**

For typical installations on flat/even ground, the posts are to be set at an elevation with approximately 2" clearance between the bottom of the bottom rail cut out and the ground. Posts are routed with a standard rail hole (rectangular cut out) which can accommodate an approximate 10% grade change (Fig. 11). For installations with more significant grades, there are two alternate methods of installation. Both will require special shop or field fabrication and therefore should be discussed with fabrication shop prior to order.

**A) RACKED INSTALLATION**

“Racked” installation enables fence sections (horizontal rails) to “follow” the sloping terrain and maintain the bottom of the fence relatively close to the ground (Fig. 11). When installing multiple sections, it is advisable to use end posts in lieu of line posts, and field fabricate the opposite side of the post to avoid a jagged fence line. Depending on the severity of the rack, special shop or field fabrication of the posts and pickets may be required which include elongating the holes in the posts to accept rails and shortening the length of pickets. In extreme cases, it may be required to decrease the spacing of post centers.

**1. Enlarge holes in post to accept rails**

- Determine angle or slope
- Set all Vinyl Posts to desired elevation
- Position rail next to post (not in routed hole) at correct angle of grade.
- Mark rail where post crosses it on angle (Fig. 12)

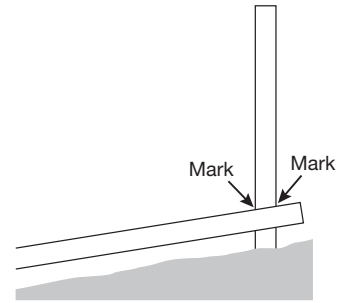

Figure 12

- Remove rail, measure the length of the drawn angle. Add 1/8" to this length to determine proper post hole size
- Enlarge post holes (Fig. 13)

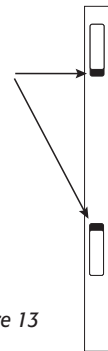

Figure 13

**NOTE:** Always open bottom of top hole and top of bottom hole to maintain proper fence height.

- Holes may be cut utilizing a template kit and router or spiral saw
- Determine location of holes on opposite side of line post by laying rail across side of post (align with routed hole) and marking exit position of rail on opposite side of post
- Cut holes with template kit and router or spiral saw as previous

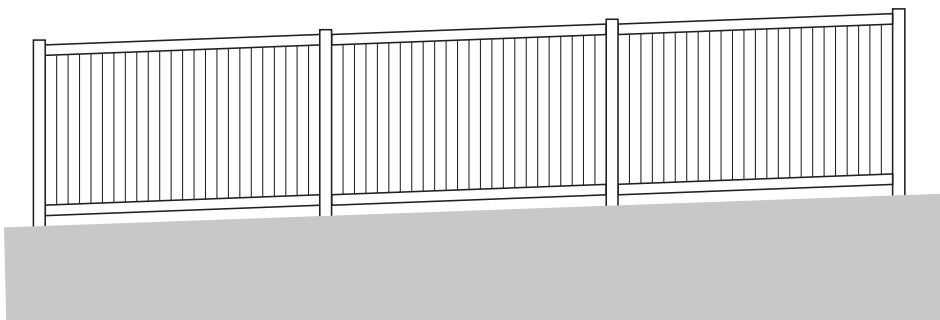

Figure 11

**2. Shorten picket length**

- For extreme racking situations, picket ends may need to be cut to accommodate rack
- Install top and bottom rails in routed post holes
- Position pickets next to rail plumb and aligned with bottom rail
- Mark position where top and bottom of picket intersects inside groove of rails; subtract 3/8" and cut picket to length

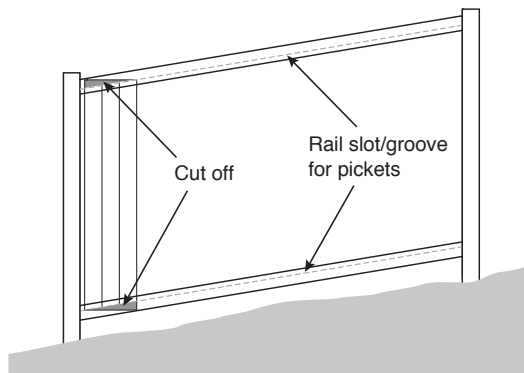

Figure 14

**B) STEPPED INSTALLATION**

“Stepped” installation enables the fence sections to maintain a horizontal profile (rails) as they step section to section. Note that the clearance under the fence section will increase as the grade drops off (Fig. 15). Posts are to be installed higher relative to the fence section on high side of the post. In order to accomplish this on a line post, the routed rail hole cut outs will have to be “offset” from one side of the post to the other. Alternately, the fabrication shop can provide a post with rail cut outs only on one side (end post) so as the other offset side can be field routed.

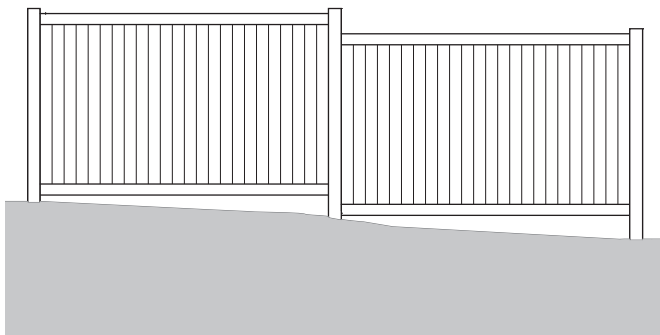

Figure 15

**6 Installing Bottom Rails**

**STEP 1**

If post spacing is less than standard 6' or 8' on center, cut a piece from the end of the top and bottom rails to achieve the desired length. The length of the top and bottom rails should be 1/2" less than the center-to-center measurement of the posts.

**STEP 2 (optional)**

Using the notching tool, notch both ends of the bottom rail with one or two notches on each side (Fig. 16). Hold the rail and the tool steady while notching, avoid twisting the tool.

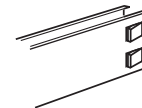

Figure 16

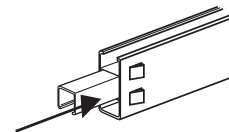

Figure 17

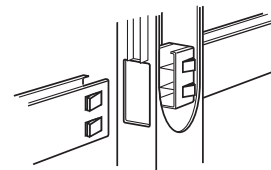

Figure 18

**STEP 3 (8' on center post spacing)**

Slide the metal reinforcing insert into the bottom rail (Fig. 17).

**STEP 4**

Slide one end of the bottom rail into the bottom hole of terminal post (Fig. 18). Then slide other end of bottom rail into next line post.

**STEP 5**

Repeat these steps proceeding down the fence line until all bottom rails are inserted.

**7 Installing Pickets**

**STEP 1**

If post spacing is less than standard 6' or 8' on center, you may need to cut equal amounts off of the grooved side of the picket on one end of the panel and the tongued side of the picket on the opposite end (Fig. 19).

**STEP 2**

Starting on one end, insert the first picket into the bottom rail and the U-channel. Proceeding down the panel, insert pickets into the bottom rail, interlocking the tongues and grooves as you go. If you have cut the first picket, the cut end should go into the U-channel. (Fig. 20). To ensure a strong, secure fence make sure the pickets are fit tight next to one another.

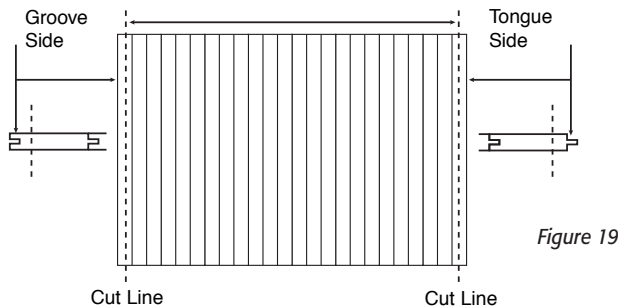

Figure 19

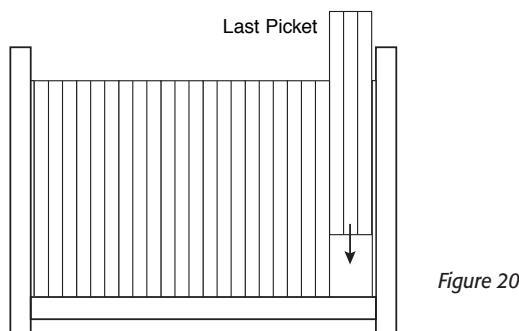

Figure 20

**8 Installing Top Rail/Accent Top**

**SENTRY TOP RAIL**

**STEP 1**

Place one end of the top rail into the post and work your way down the panel inserting pickets into the top rail as you go (Fig. 21).

**STEP 2**

Once all of the pickets are installed, slide the loose rail end into the post (Fig. 22).

**Repeat these steps until all panels have been assembled.**

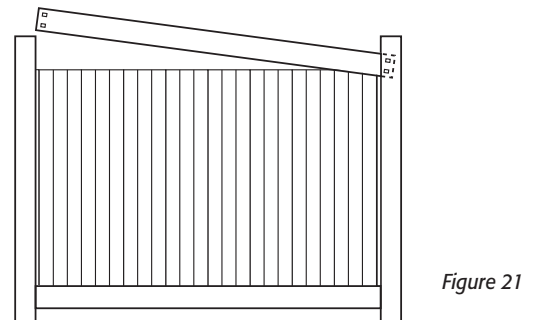

Figure 21

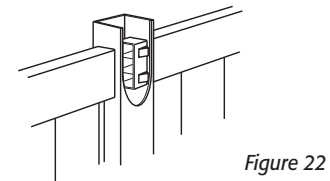

Figure 22

**STEP 3 (optional)**

To secure rails, drill a screw diagonally into each top rail through top inside of posts (Fig.23).

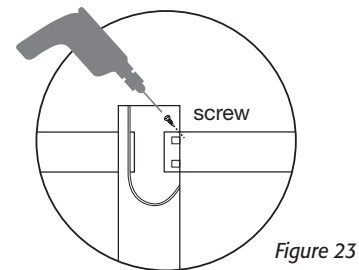

Figure 23

**ESTATE PICKET ACCENT TOP**

**STEP 1**

Install mid rail as per Step 1 & 2 of Sentry Top Rail installation. Note that square holes in mid rail are to face upwards (Fig. 24).

**STEP 2**

If post spacing is less than standard 6' or 8' on center, you may need to cut some from each end of rail to ensure that the distance from the post to the first picket remains equal on each end (Fig. 25). The length of the top and bottom rails should be 1" less than the center-to-center measurement of the posts.

**STEP 3**

Slide 7/8" x 1 1/2" x 12" accent pickets into the routed holes in the top of the mid rail (Fig. 26).

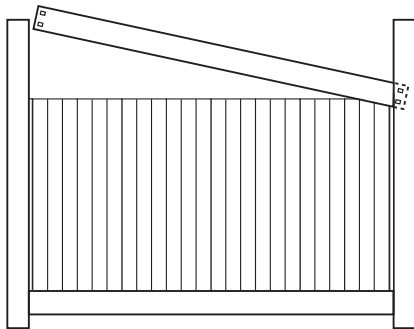

Figure 24

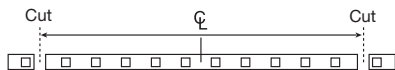

Figure 25

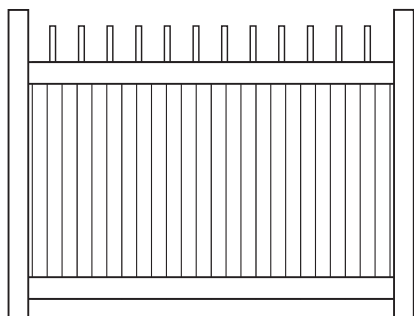

Figure 26

**STEP 4**

Place one end of the 2" x 3 1/2" top rail into the post and work your way down the panel inserting pickets into the top rail as you go (Fig. 27).

Once all of the pickets are installed, slide the loose rail end into the post (Fig. 28).

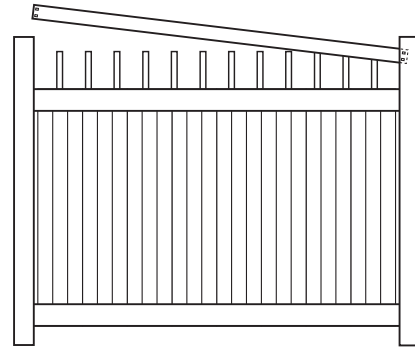

Figure 27

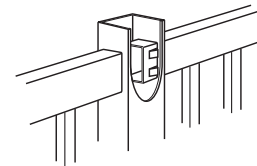

Figure 28

**STEP 5 (optional)**

To secure top rails, drill a screw diagonally into each top rail through top inside of posts (Fig. 23).

**MANOR LATTICE ACCENT TOP**

**STEP 1**

Install mid rail as per Step 1 & 2 of Sentry Top Rail installation. Note that the side with the narrower routed slot is to face upwards (Fig. 29).

**STEP 2**

Slide 12" x 6' or 8' accent lattice into the routed slot in the top of the mid rail (Fig. 30).

**STEP 3**

Place one end of the 2" x 3 1/2" top rail into the post and work your way down the panel inserting lattice into the top rail slot as you go (Fig. 31).

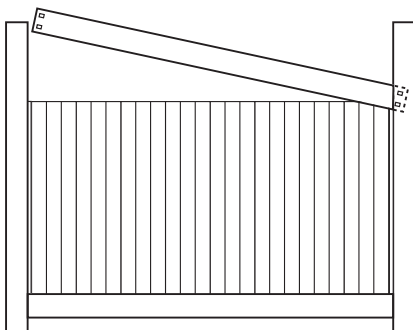

Figure 29

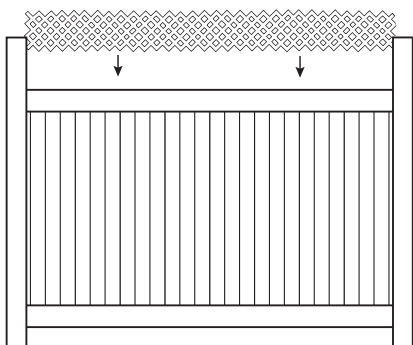

Figure 30

**STEP 4**

Once all of the lattice is installed, slide the loose rail end into the post (Fig. 32).

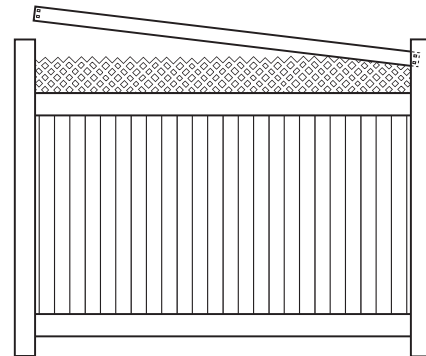

Figure 31

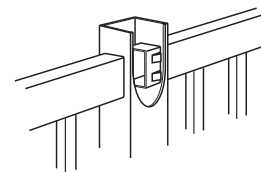

Figure 32

**STEP 5 (optional)**

To secure rails, drill a screw diagonally into each top rail through top inside of posts (Fig. 23).

**9 Installing Post Caps (optional)**

**NOTE:** Do not install post caps on gate posts until gate installation is complete.

**EXTERNAL CAPS** (*slide over the post*)

Apply PVC glue to the inside of the cap and press completely onto the top of the post (Fig. 33). Press firmly to ensure that the cap is on as far as it will go.

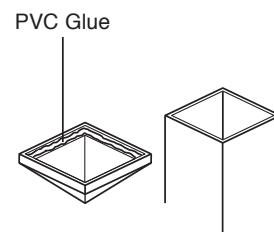

Figure 33

**10 Gate Installation**

**PRIVACY GATE PARTS LIST**

Available in 4', 5' and 6' heights.

- Standard walk gate “opening width” is 43”
- Opening width is the inside post to inside post measurement
- Gates are manufactured 1-1/2” narrower than the opening width to provide clearance for latches and hinges.

**EACH PRIVACY GATE INCLUDES:**

- Gate Panel
- Heavy Duty Latch (1)
- Heavy Duty Hinges (2)
- Gate Hinge Post on Steel L-Channel Reinforcing Insert (“Dug & Poured” in concrete pile) (1)
- Gate Latch Post on Post Mount (1)

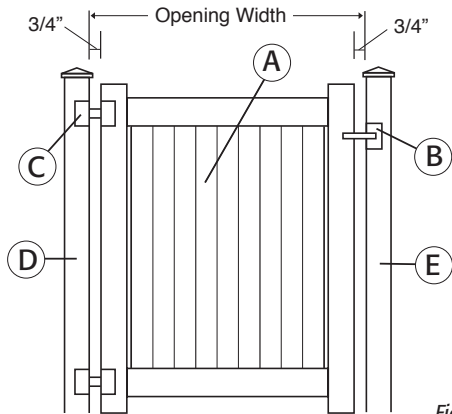

Figure 34

**HANGING THE GATE**

**STEP 1**

Position the gate in the gate opening and block-up the gate as necessary to line up the horizontal gate rails with those of the fence (Fig. 35). Attach hinges and latch to the gate and posts per the installation instructions packaged with the hardware.

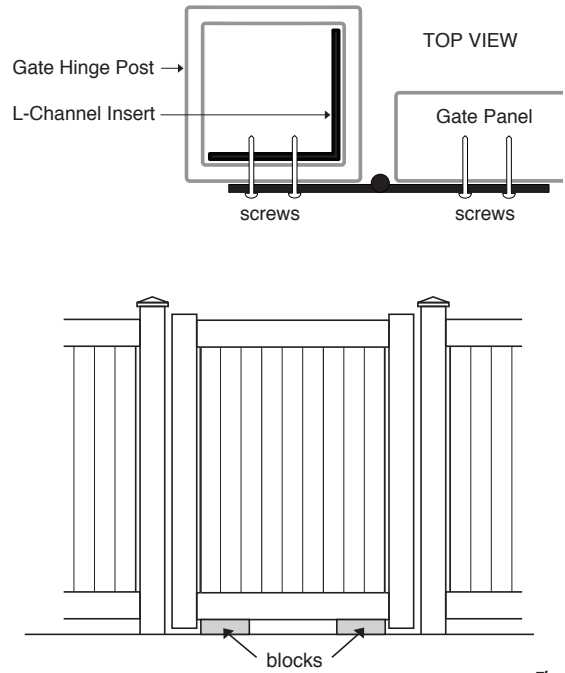

Figure 35

**STEP 2**

Install gate post caps (refer to Section 9 - Installing Post Caps).