



# PHOENIX FENCE

## EDMONTON

12816-156 STREET T5V 1E9  
 PHONE: (780) 447-1919  
 FAX: (780) 447-2512  
 TOLL FREE: 1-800-661-9847  
 E-MAIL: phoenix@phoenixfence.ca

## CALGARY

6204-2nd STREET S.E. T2H 1J4  
 PHONE: (403) 259-5155  
 FAX: (403) 259-2262  
 TOLL FREE: 1-888-220-2525  
 E-MAIL: calgary@phoenixfence.ca

WEBSITE: www.phoenixfence.ca

## Backstop – No Overhang

### Normal sizes in combination of:

A	B	H
10'	10'	10'
15'	15'	12'
20'	20'	16'

### By Quotation

- Custom designed backstops
- Complete ballfield fencing
- Material only or professionally installed

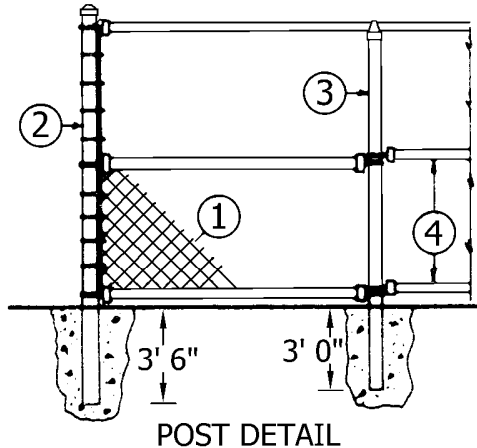
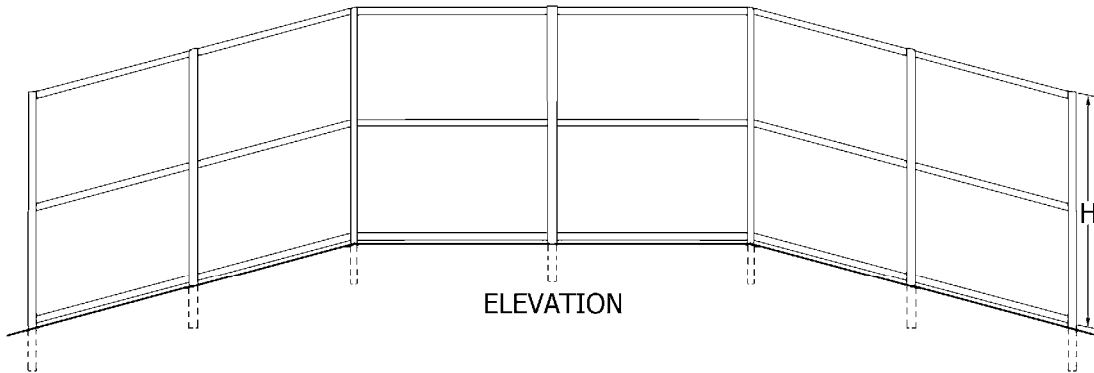
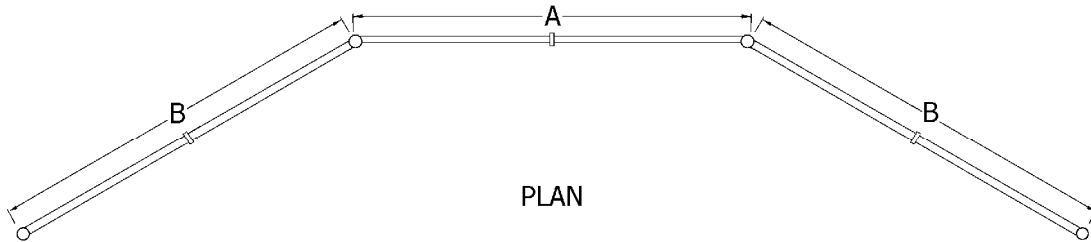

### Specifications:

1. FABRIC – 2" x 9 gauge galvanized chain link
2. TERMINAL POSTS – 2 7/8" O.D. galvanized pipe
3. LINE POSTS – 2 3/8" O.D. galvanized pipe
4. TOP, CENTER, BOTTOM RAILS – 1 5/8" O.D. galvanized pipe complete with all fittings and hardware.